



SPECIFICATION SHEET

FR SERIES

FR 40/60: 40,000 - 60,000 LBS. (18 - 27 TONNES)



FR SERIES: STANDARD & OPTIONAL EQUIPMENT

Operator Cab

- Meets ANSI B56.1 FOPS operator protection
- Left-hand operator position for optimal line of sight
- Rubber-mounted cab isolated from the frame to reduce noise and vibration
- Overhead guard provides safety without obstructing views
- Low, non-skid steps for safe and easy entry/exit
- Adjustable semi-suspension seat and retractable seat belts
- Onboard Load Calculator provides capacities for forks and boom for all counterweight slab variations and chassis extension positions
- Master digital display unit provides all vehicle gauges (e.g. oil temperature, fuel level)
- Engine fault code diagnostic capability
- Soft-touch hydraulic levers
- Tilt-steering column
- Spring-apply/hydraulic-release parking brake
- Hydraulic weight scale

Mast & Carriage

- Quick-Change Fork System for quick connect/disconnect of attachments
- Heavy-duty mast rails provide visibility and full capacity at maximum lift heights
- High-strength adjustable composite wear pads on boom
- Main and side thrust rollers are impact-resistant and designed to reduce friction
- Greaseable mast pivots constructed with wear-resistant bronze bushings and hardened steel pins
- Safety valve built into base of lift cylinder securely holds load in event of hose failure
- Chrome-plated cylinder rods

Power

- GM 3.0L LPG
- Electronic engine diagnostics with fault code history
- Built-in Engine protection system
- Heavy-duty isolated anti-vibration bolt-in drive line mounts
- Inboard muffler
- Heavy-duty alternator with built-in regulator
- Externally mounted charge pump and integral filter allow for easy maintenance
- O-ring face seal fittings on entire system prevent oil leaks
- Tilt-lock counterbalance valve to prevent mast drift
- Easy-access oil filter and drain for quick and easy maintenance
- Large clean-out covers on top of hydraulic tank for easy access and convenient drain plug on the bottom
- Filters are easily accessible for quick replacement
- Hydraulic multi-gauge provides quick and easy pressure readings with a twist of the dial; eliminates the need to tap into hydraulic lines
- Standard 12-volt electrical system
- Color-coded electrical wires enclosed with split-tubing wire loom wrap using sealed weather pack connectors

Strength

- Planetary drive axle rated for durability in high-capacity, high-torque applications
- Double reduction gearing for increased torque
- Precision ground, heat-treated gears

Industrial Steer Axle

- Thick top plate on welded beam steer axle provides added strength
- Highly maneuverable in tight areas
- Dual-action bolt-on cylinder is protected by heavy steel support beams and provides effortless power steering
- Lower maintenance costs due to minimal amount of moving parts
- Easy-access lubrication points
- Tapered roller bearings
- High-impact greaseable composite trunnions

Paint/Finish

- Two-part rust-inhibiting polyurethane base coat and two-part polyurethane top coat for corrosion protection
- Majority of components are powder-coated, which is up to 10 times thicker than traditional spray paint resulting in greater scratch and chip resistance
- Environmentally friendly; produces virtually no VOC's

Serviceability

- Hinged panels and hoods supported by gas shocks to reach entire drivetrain, hydraulics and filters
- Hydraulic multi-gauge provides quick and easy pressure readings with a twist of the dial, eliminating the need to tap into individual hydraulic lines
- Every component sourced from a reputable vendor or manufactured by Hoist Lifteruck providing cost savings and rapid parts availability

Optional Equipment & Features

- Remote control for all vehicle functions
- Fire extinguisher
- Single- or dual-camera/monitor packages
- Additional two-stage mast options for increased lift heights
- Side-shifting, independent fork positioner (SS/FP)
- Boom attachments: hooks, shackles, swivels and more
- Lifting ring assemblies (slides over boom for 2 pc. picks)
- Additional work lights
- "Blue Spot" Safety Light
- Hydraulic service brakes



FR SERIES 40/60

40,000/60,000 LBS. (18-27 TONNES)

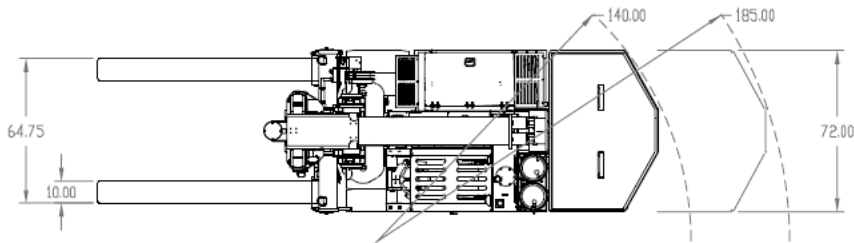

WEIGHTS - LBS (KG)	
REMOVEABLE COUNTERWEIGHT	16,240 (7,366)
BOOM	5,480 (2,486)
FORKS	3,100 (1,406)
TOTAL	58,860 (26,699)

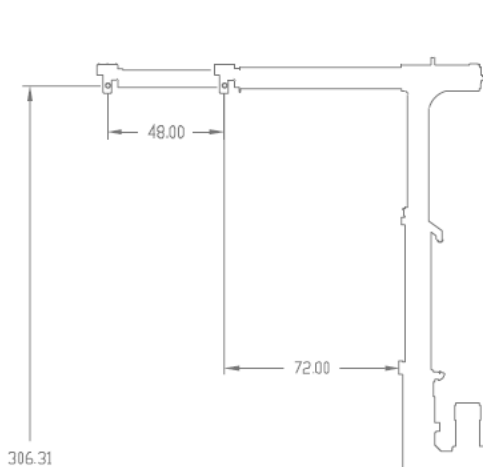

COUNTERWEIGHT EXTENSION - in (mm)	WHEELBASE IN (MM)	LOAD CENTER IN (MM)	# OF SLABS	LIFT CAPACITY LBS (KG)
0 (0)	98 (2,500)	36 (900)	0	20,900 (9,480)
0 (0)	98 (2,500)	36 (900)	7	41,600 (18,869)
48 (1,200)	146 (3,700)	36 (900)	0	30,800 (13,971)
48 (1,200)	146 (3,700)	36 (900)	7	61,400 (27,851)

COUNTERWEIGHT EXTENSION - in (mm)	WHEELBASE IN (MM)	LOAD CENTER IN (MM)	# OF SLABS	LIFT CAPACITY LBS (KG)
0 (0)	98 (2,500)	36 (900)	0	17,400 (7,893)
0 (0)	98 (2,500)	36 (900)	7	33,600 (15,241)
48 (1,200)	146 (3,700)	36 (900)	0	25,100 (11,385)
48 (1,200)	146 (3,700)	36 (900)	7	48,100 (22,271)

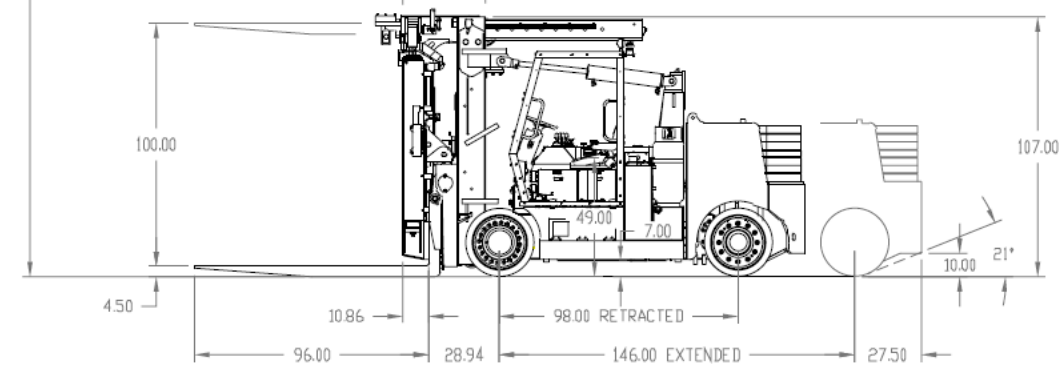

**CAPACITIES (Lbs)
WITH 0 COUNTERWEIGHT SLABS**

FORKS ONLY	COUNTERWEIGHT EXTENSION (in)				
	0"	12"	24"	36"	48"
36" LC	20,900	23,400	25,800	28,300	30,800
48" LC	17,700	19,800	21,800	23,900	26,000
60" LC	15,300	17,100	18,900	20,700	22,500
72" LC	13,500	15,100	16,700	18,300	19,900
84" LC	12,100	13,500	14,900	16,300	17,800

BOOM ONLY	COUNTERWEIGHT EXTENSION (in)				
	0"	12"	24"	36"	48"
24" LC	20,700	22,900	25,300	27,600	29,900
36" LC	17,400	19,300	21,300	23,200	25,100
48" LC	15,000	16,600	18,400	20,000	21,700
60" LC	13,200	14,600	16,200	17,600	19,100
72" LC	11,700	13,000	14,200	15,600	16,900
78" LC	11,100	12,300	13,500	14,700	16,100
84" LC	10,500	11,700	12,900	14,000	15,300
90" LC	10,100	11,200	12,300	13,400	14,500
96" LC	9,600	10,700	11,700	12,800	13,800
102" LC	9,200	10,200	11,200	12,200	13,200
108" LC	8,800	9,800	10,800	11,700	12,700
114" LC	8,500	9,400	10,300	11,300	12,200
120" LC	8,200	9,100	10,000	10,900	11,800

**CAPACITIES (Lbs)
WITH 1 COUNTERWEIGHT SLABS**

FORKS ONLY	COUNTERWEIGHT EXTENSION (in)				
	0"	12"	24"	36"	48"
36" LC	23,800	26,700	29,500	32,300	35,100
48" LC	20,200	22,600	24,900	27,300	29,700
60" LC	17,500	19,500	21,600	23,700	25,700
72" LC	15,400	17,200	19,100	20,900	22,700
84" LC	13,800	15,400	17,000	18,700	20,300

BOOM ONLY	COUNTERWEIGHT EXTENSION (in)				
	0"	12"	24"	36"	48"
24" LC	23,500	26,000	28,700	31,400	34,000
36" LC	19,700	21,900	24,200	26,300	28,500
48" LC	17,000	18,800	20,900	22,700	24,600
60" LC	15,000	16,600	18,400	20,000	21,700
72" LC	13,300	14,800	16,200	17,700	19,200
78" LC	12,600	14,000	15,400	16,700	18,300
84" LC	11,900	13,300	14,600	15,900	17,400
90" LC	11,400	12,700	14,000	15,200	16,500
96" LC	10,900	12,100	13,300	14,500	15,700
102" LC	10,400	11,600	12,700	13,900	15,000
108" LC	10,000	11,100	12,300	13,300	14,400
114" LC	9,600	10,700	11,700	12,800	13,900
120" LC	9,300	10,100	10,900	11,700	12,400

**CAPACITIES (Lbs)
WITH 2 COUNTERWEIGHT SLABS**

FORKS ONLY	COUNTERWEIGHT EXTENSION (in)				
	0"	12"	24"	36"	48"
36" LC	26,800	30,000	33,200	36,300	39,500
48" LC	22,700	25,400	28,000	30,700	33,400
60" LC	19,600	22,000	24,300	26,600	28,900
72" LC	17,300	19,400	21,400	23,500	25,500
84" LC	15,500	17,300	19,200	21,000	22,800

BOOM ONLY	COUNTERWEIGHT EXTENSION (in)				
	0"	12"	24"	36"	48"
24" LC	26,200	29,100	32,200	35,100	38,100
36" LC	22,000	24,500	27,000	29,500	32,000
48" LC	19,000	21,100	23,300	25,400	27,600
60" LC	16,700	18,500	20,500	22,300	24,300
72" LC	14,800	16,500	18,100	19,900	21,500
78" LC	14,100	15,600	17,200	18,800	20,500
84" LC	13,300	14,900	16,400	17,900	19,500
90" LC	12,800	14,200	15,600	17,100	18,500
96" LC	12,200	13,600	14,900	16,300	17,600
102" LC	11,700	13,000	14,300	15,600	16,900
108" LC	11,200	12,500	13,700	14,900	16,200
114" LC	10,800	11,900	13,100	14,400	15,600
120" LC	10,400	11,100	11,800	12,400	13,100

**CAPACITIES (Lbs)
WITH 3 COUNTERWEIGHT SLABS**

FORKS ONLY	COUNTERWEIGHT EXTENSION (in)				
	0"	12"	24"	36"	48"
36" LC	29,800	33,300	36,800	40,400	43,900
48" LC	25,200	28,200	31,100	34,100	37,100
60" LC	21,800	24,400	27,000	29,600	32,100
72" LC	19,200	21,500	23,800	26,100	28,300
84" LC	17,200	19,200	21,300	23,300	25,400

BOOM ONLY	COUNTERWEIGHT EXTENSION (in)				
	0"	12"	24"	36"	48"
24" LC	29,000	32,200	35,600	38,900	42,200
36" LC	24,300	27,100	29,900	32,600	35,400
48" LC	21,000	23,300	25,800	28,100	30,500
60" LC	18,500	20,500	22,700	24,700	26,900
72" LC	16,400	18,300	20,100	22,000	23,800
78" LC	15,600	17,300	19,100	20,800	22,700
84" LC	14,700	16,500	18,100	19,800	21,600
90" LC	14,100	15,700	17,300	18,900	20,500
96" LC	13,500	15,000	16,500	18,000	19,500
102" LC	12,900	14,400	15,800	17,300	18,700
108" LC	12,400	13,800	15,200	16,500	17,900
114" LC	11,900	13,200	14,500	15,900	17,300
120" LC	11,500	12,100	12,700	13,200	13,700



**CAPACITIES (Lbs)
WITH 4 COUNTERWEIGHT SLABS**

FORKS ONLY	COUNTERWEIGHT EXTENSION (in)				
	0"	12"	24"	36"	48"
36" LC	32,700	36,600	40,500	44,400	48,300
48" LC	27,700	31,000	34,200	37,500	40,800
60" LC	24,000	26,800	29,700	32,500	35,300
72" LC	21,100	23,600	26,200	28,700	31,200
84" LC	18,900	21,100	23,400	25,600	27,900

BOOM ONLY	COUNTERWEIGHT EXTENSION (in)				
	0"	12"	24"	36"	48"
24" LC	31,800	35,300	39,000	42,600	46,300
36" LC	26,700	29,600	32,800	35,800	38,800
48" LC	23,000	25,600	28,200	30,800	33,500
60" LC	20,200	22,500	24,800	27,100	29,400
72" LC	17,900	20,000	22,000	24,100	26,200
78" LC	17,000	18,900	20,900	22,800	24,800
84" LC	16,200	18,000	19,900	21,700	23,600
90" LC	15,500	17,200	18,900	20,800	22,500
96" LC	14,700	16,500	18,100	19,800	21,500
102" LC	14,100	15,700	17,300	18,900	20,600
108" LC	13,500	15,100	16,600	18,200	19,700
114" LC	13,100	14,500	16,000	17,500	18,900
120" LC	12,500	13,200	13,500	13,900	14,300



**CAPACITIES (Lbs)
WITH 5 COUNTERWEIGHT SLABS**

FORKS ONLY	COUNTERWEIGHT EXTENSION (in)				
	0"	12"	24"	36"	48"
36" LC	35,700	39,900	44,200	48,400	52,600
48" LC	30,200	33,800	37,300	40,900	44,500
60" LC	26,100	29,200	32,300	35,400	38,500
72" LC	23,000	25,800	28,500	31,300	34,000
84" LC	20,600	23,100	25,500	28,000	30,400

BOOM ONLY	COUNTERWEIGHT EXTENSION (in)				
	0"	12"	24"	36"	48"
24" LC	34,600	38,400	42,400	46,400	50,400
36" LC	29,000	32,200	35,700	38,900	42,200
48" LC	25,000	27,800	30,700	33,500	36,400
60" LC	22,000	24,500	27,000	29,500	32,000
72" LC	19,500	21,800	24,000	26,200	28,500
78" LC	18,500	20,600	22,800	24,800	27,000
84" LC	17,600	19,600	21,600	23,600	25,700
90" LC	16,800	18,700	20,600	22,600	24,500
96" LC	16,000	17,900	19,700	21,500	23,400
102" LC	15,300	17,100	18,800	20,600	22,400
108" LC	14,700	16,400	18,100	19,800	21,400
114" LC	14,200	15,800	17,400	19,000	20,600
120" LC	13,600	14,200	14,400	14,700	14,900



**CAPACITIES (Lbs)
WITH 6 COUNTERWEIGHT SLABS**

FORKS ONLY	COUNTERWEIGHT EXTENSION (in)				
	0"	12"	24"	36"	48"
36" LC	38,600	42,200	47,800	52,400	57,000
48" LC	32,700	36,600	40,400	44,300	48,200
60" LC	28,300	31,700	35,000	38,400	41,700
72" LC	25,000	27,900	30,900	33,900	36,800
84" LC	22,300	25,000	27,600	30,300	32,900

BOOM ONLY	COUNTERWEIGHT EXTENSION (in)				
	0"	12"	24"	36"	48"
24" LC	37,300	41,500	45,900	50,100	54,500
36" LC	31,300	34,800	38,500	42,100	45,700
48" LC	27,000	30,100	33,100	36,200	39,400
60" LC	23,700	26,400	29,100	31,800	34,600
72" LC	21,000	23,500	25,900	28,400	30,800
78" LC	20,000	22,200	24,600	26,900	29,200
84" LC	19,000	21,200	23,400	25,600	27,800
90" LC	18,200	20,200	22,200	24,500	26,500
96" LC	17,300	19,400	21,300	23,300	25,300
102" LC	16,600	18,500	20,400	22,300	24,300
108" LC	15,900	17,800	19,500	21,400	23,200
114" LC	15,400	17,000	18,800	20,600	22,300
120" LC	14,700	15,200	15,300	15,400	15,600

**CAPACITIES (Lbs)
WITH 7 COUNTERWEIGHT SLABS**

FORKS ONLY	COUNTERWEIGHT EXTENSION (in)				
	0"	12"	24"	36"	48"
36" LC	41,600	46,500	51,500	56,400	61,400
48" LC	35,200	39,400	43,500	47,700	51,900
60" LC	30,500	34,100	37,700	41,300	44,900
72" LC	26,900	30,100	33,300	36,500	39,600
84" LC	24,000	27,900	29,700	32,600	35,500

BOOM ONLY	COUNTERWEIGHT EXTENSION (in)				
	0"	12"	24"	36"	48"
24" LC	40,100	44,600	49,300	53,900	58,600
36" LC	33,600	37,400	41,400	45,200	49,100
48" LC	29,000	32,300	35,600	38,900	42,300
60" LC	25,500	28,400	31,300	34,200	37,200
72" LC	22,600	25,300	27,900	30,500	33,100
78" LC	21,500	23,900	26,500	28,900	31,400
84" LC	20,400	22,800	25,100	27,500	29,900
90" LC	19,500	21,700	23,900	26,300	28,500
96" LC	18,600	20,800	22,900	25,000	27,200
102" LC	17,800	19,900	21,900	24,000	26,100
108" LC	17,100	19,100	21,000	23,000	24,900
114" LC	16,500	18,300	20,200	22,100	24,000
120" LC	15,800	16,200	16,200	16,200	16,200

